

1. Coiler
2. Push rod hose
3. Front Mobility Wheels
4. Rear Mobility Wheels
5. Pulling motors
6. Transportation handles
7. Air valve
8. Power socket
9. Pulling motors power cable
10. Control unit
11. 7" Auxiliary display screen
12. Silencer
13. Air Pressure valve
14. Water Filter
15. Electronic pressure sensor
16. Manometer / pressure gauge
17. Curing Head
18. ON / OFF Button
19. Emergency Stop
20. USB port
21. Internet connection port
22. Working control display
23. TFT monitor (camera display)
24. Foldable Table
25. Identification Plate

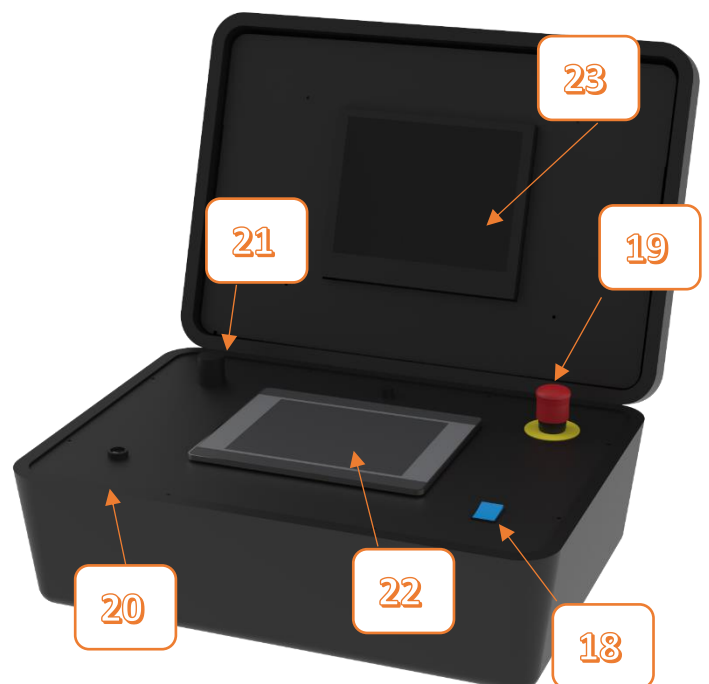
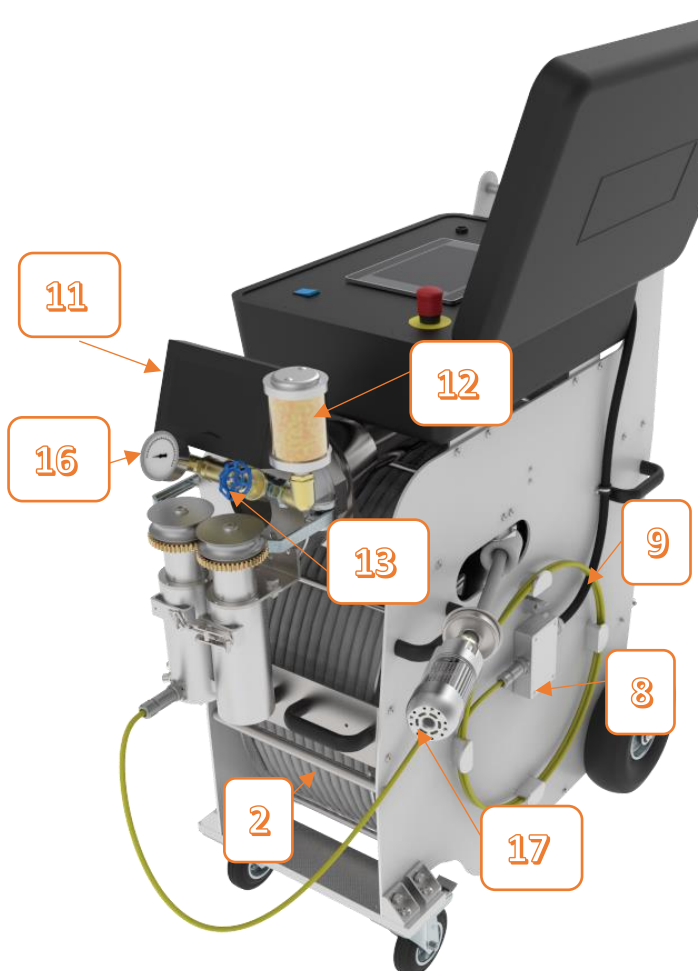

Physical

Dimensions (LxWxH)	1461,8 x 543 x 1080 cm
Total Weight	123 kg (incl. 100 hose)
Material	Chassis based on stainless steel, aluminium, ABS
Support	Structure with 4 wheels

Computer

HMI	9,7" Weintek MT8090XE
PLC	Siemens Simatic

Display

Main Monitor	10" installed within the C.U
Auxiliary Monitor	7" installed withing the P.U

Connectivity

Wi-Fi connectivity	2,4 GHz
Mode	AP
Internet Access	Socket RJ45 WAN, Mobile tethering via USB

Safety

Auto-stop function	Yes, by sensor of contact Yes, Emergency Stop Button
Emergency Stop	installed within the Control Unit Additional
Power	RCD switch

Power requirements

Voltage	110 – 230V 50/60 Hz
Mains requirement	E-type or Std. Schuko wall socket
Conection	5 m power cord with V-lock system
Power	8,5A 220V / 17A 110V
Mains requirement	Std. Schuko wall socket

UV-C Light Source

UV light source	UV LED
UV-C peak wavelength	400 nm
Lamps Life (60.000 cycles@15 m)	1000 h

Curing Head

SpectraLight XS	300W
SpectraLight S	600W
SpectraLight L	1200W
SpectraLight XL	1800W

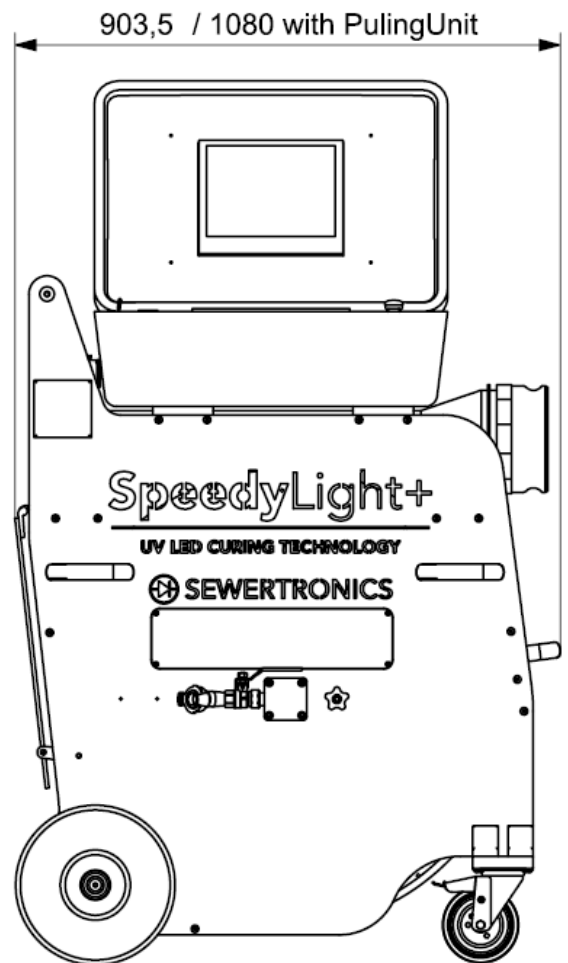
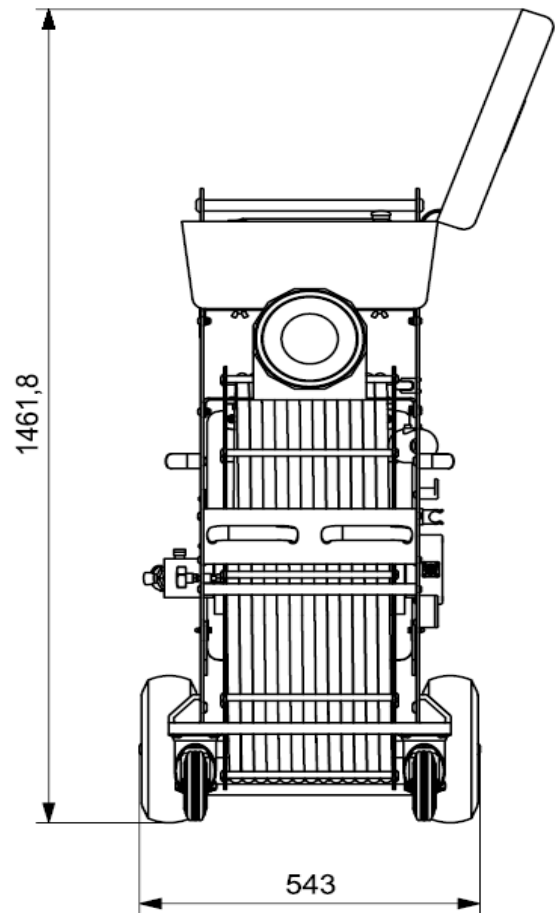

Curing Heads – SpectraLight

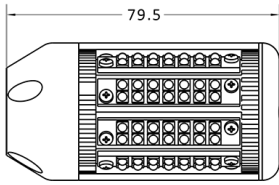

Spectra 300W

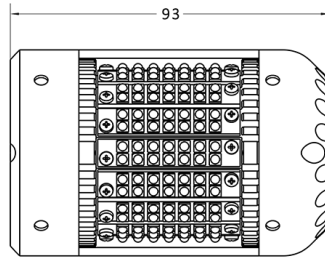

Spectra 600W

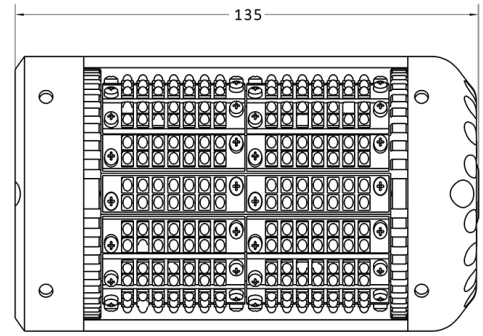

Spectra 1200W

